

The background is a dark blue gradient with a subtle pattern of white dots. On the left side, there are several circular and semi-circular graphic elements. A prominent one is a large arc with a scale from 140 to 260 in increments of 10. Other elements include smaller circles, some with arrows, and dashed lines, creating a technical or musical aesthetic.

ONLINE JAMS AND REHEARSALS

FABIO MARRACCINI

[HTTPS://AUDIOGEEK11.COM](https://audiogEEK11.com)

THE DIFFERENCE

Online Jam

- Low Latency
- Multiple Players

- Jamulus (open source, Volker Fischer)
- JamKazam
- JackTrip (open source, Chris Chafe and Juan Pablo Caceres at Stanford University)
- SoundJack (Alexander Carot)

Remote Collab

- Quality
- Sync remote takes

- Audiobridge
- Audio Movers
- Connection Open
- BandLab
- Soundwhale

<https://audiogeek11.com/best-services-for-online-music-jam-2020/>

<https://audiogeek11.com/jam-music-online-with-jamulus/>

GOOGLE TRENDS

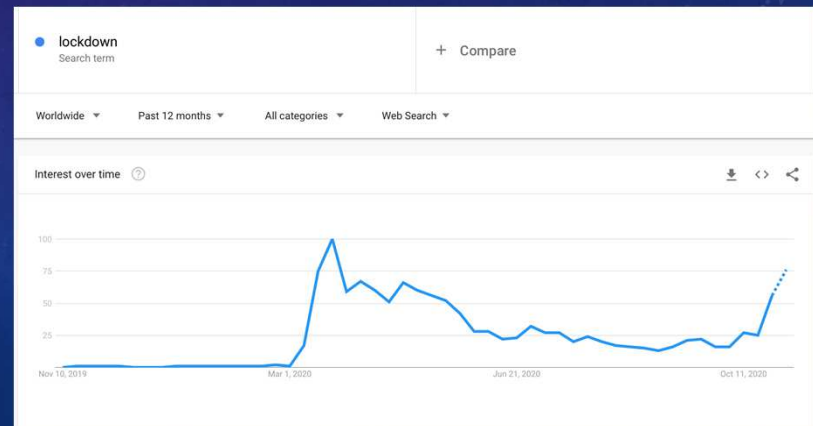
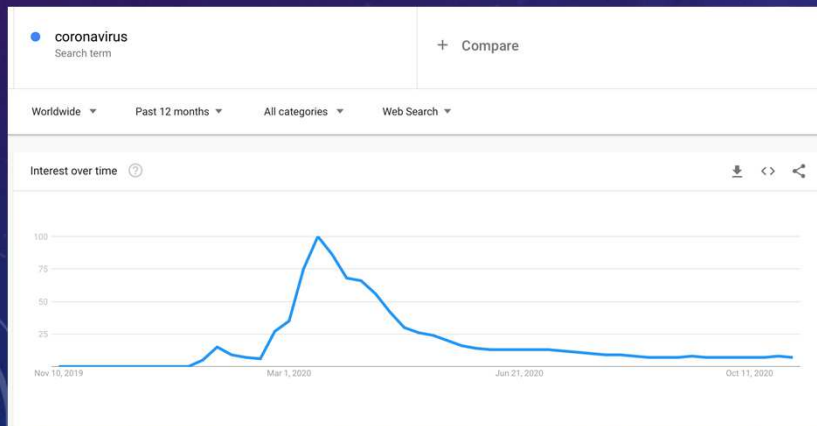
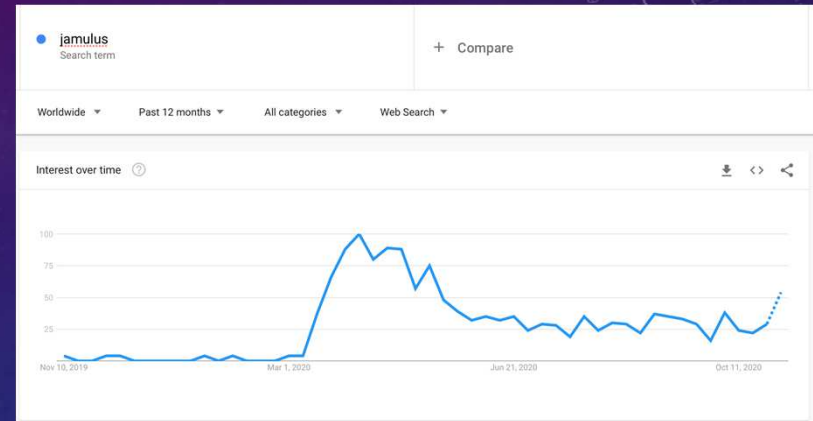
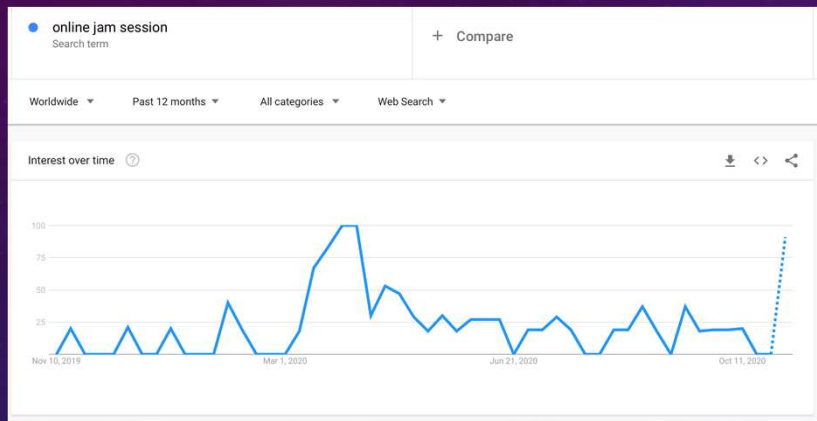

JAMULUS NETWORK DIAGRAM

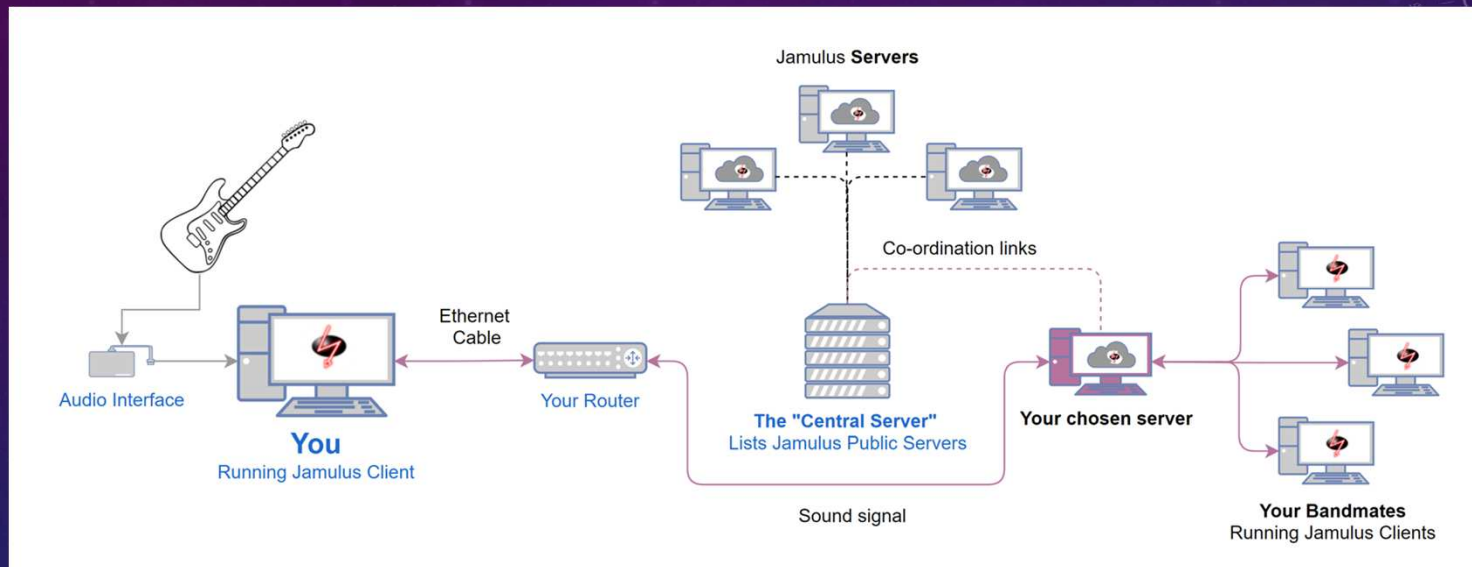

- Interface latency (RME, UA, Focusrite, etc) + gear or software latency (more on this later)
- Ping times and network latency (Ethernet recommended)
- Jamulus Buffering

PING TIMES, BANDWIDTH, LATENCY

	Adelaide	Brisbane	Melbourne	Perth	Sydney
Adelaide	—	35.761ms	12.833ms	29.698ms	23.872ms
Auckland	50.149ms	40.762ms	34.774ms	69.99ms	23.945ms
Brisbane	36.618ms	—	28.889ms	64.202ms	17.692ms
Los Angeles	176.798ms	154.179ms	149.925ms	185.223ms	137.779ms
Melbourne	13.186ms	28.832ms	N/A	36.201ms	11.587ms
Perth	33.221ms	64.268ms	36.124ms	—	46.98ms
Sydney	26.9ms	17.688ms	12.001ms	47.067ms	N/A
Tokyo	121.272ms	130.499ms	127.058ms	111.894ms	114.202ms

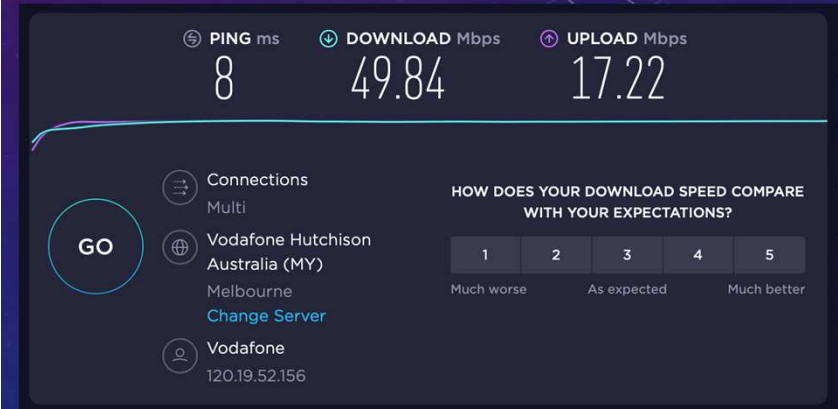

- A typical jam might have 4 people, for which you would need $200\text{Kbps} * 4 = 800\text{Kbs}$ (0.8Mbps) up and down
- Overall latency 30~50 ms is normally reasonable for a jam, so ping time 20~30ms.
- <https://www.speedtest.net>
- <https://wondernetwork.com/pings/>

JAMULUS BLOCK DIAGRAM

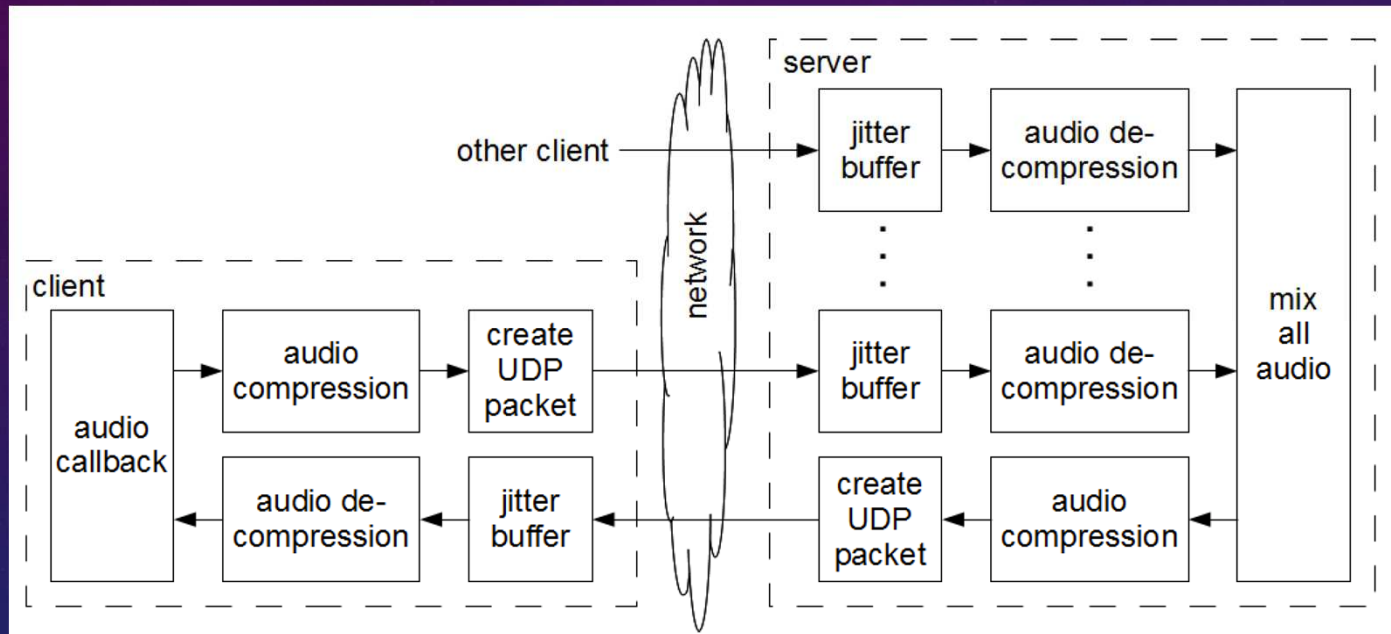

- Based on UDP and uses OPUS low-latency audio codec
- CoreAudio (MacOS), ASIO (Windows), Jackaudio (Linux)
- Any server should have at least 1.6GHz CPU frequency and 1GB RAM

BASIC ROUTING / MONITORING (DIRECT?)

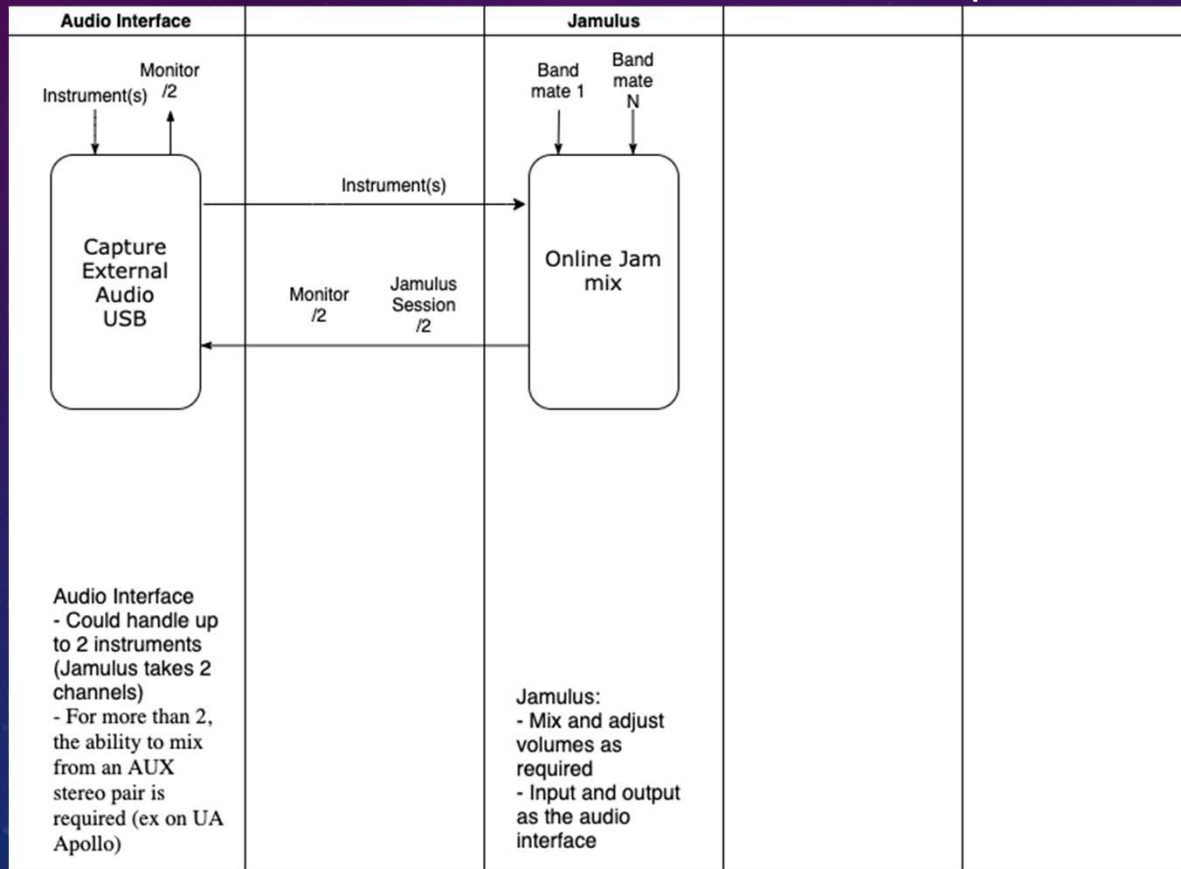

EXAMPLE OF A SESSION

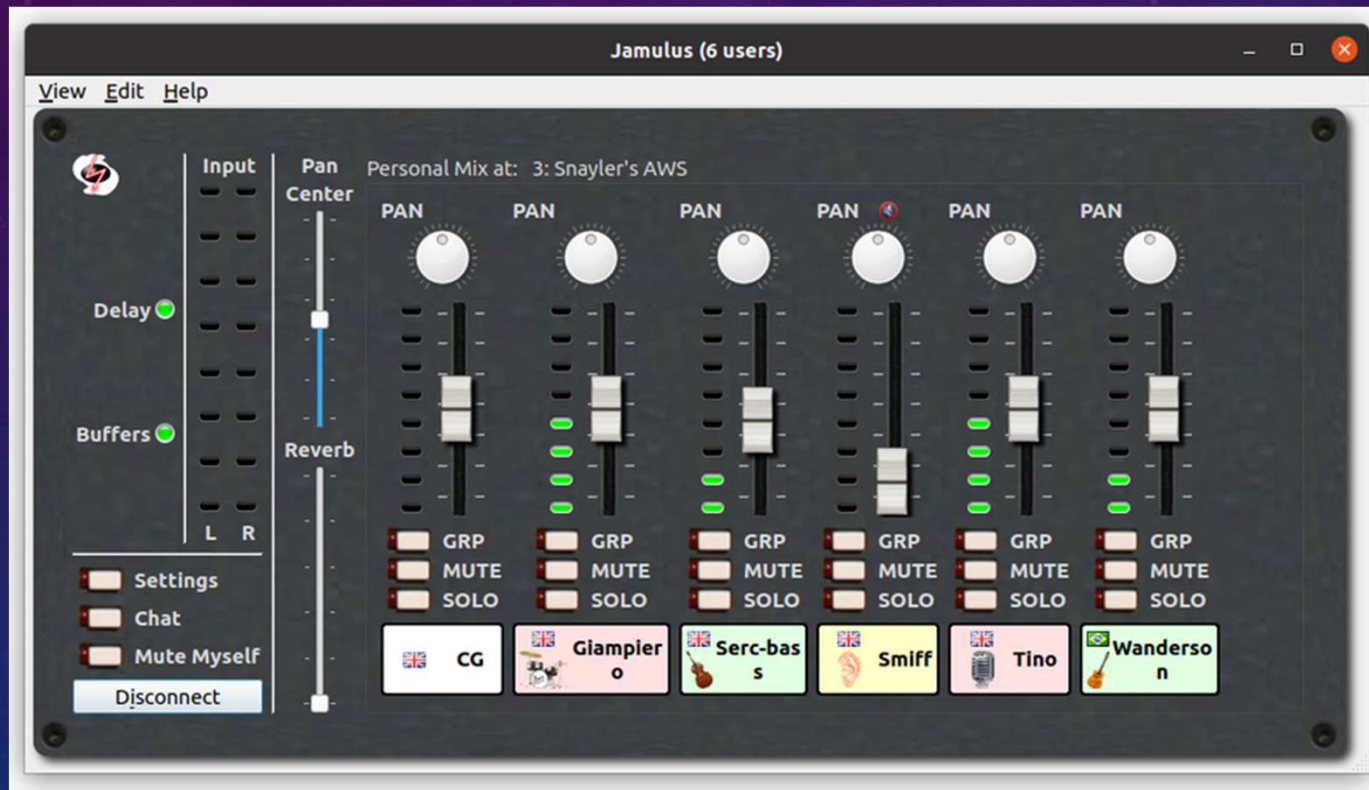

ROUTING PROCESSED AUDIO

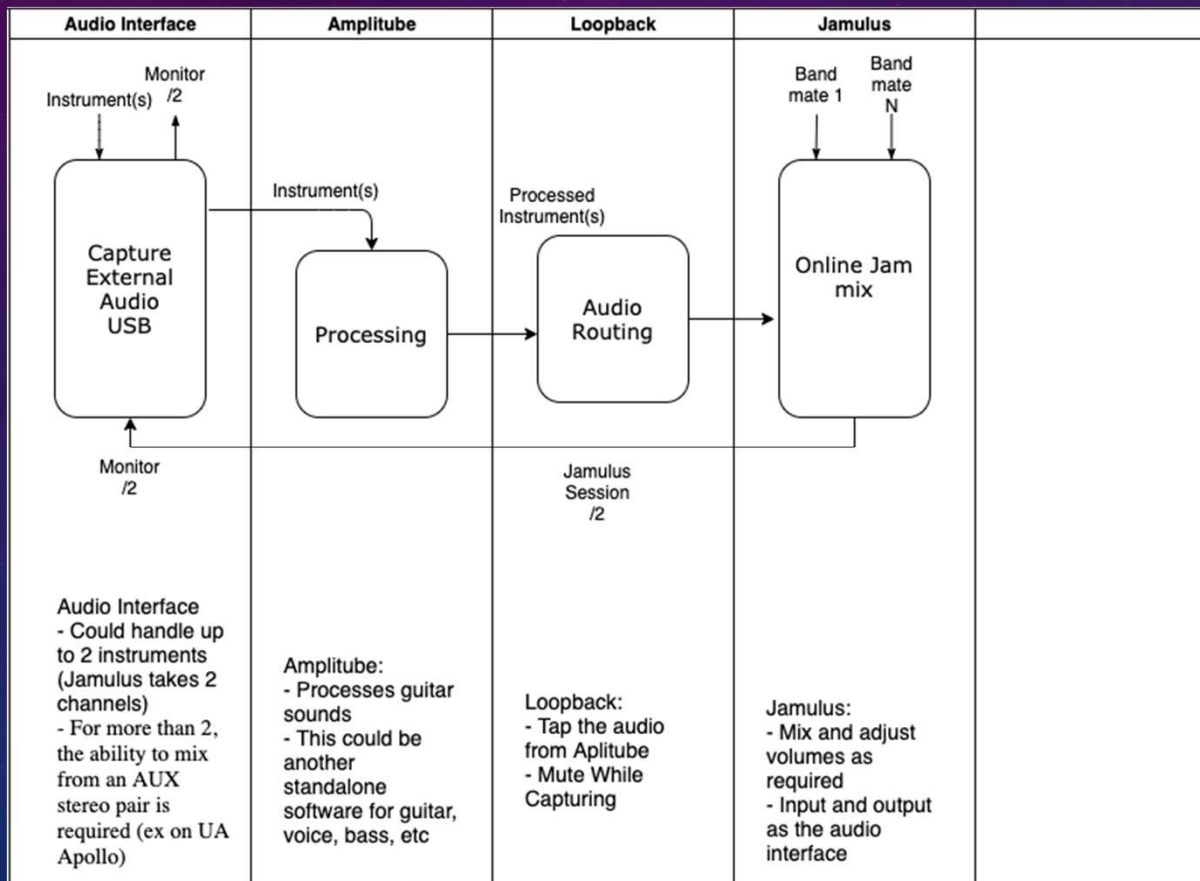

ROUTING A MIX

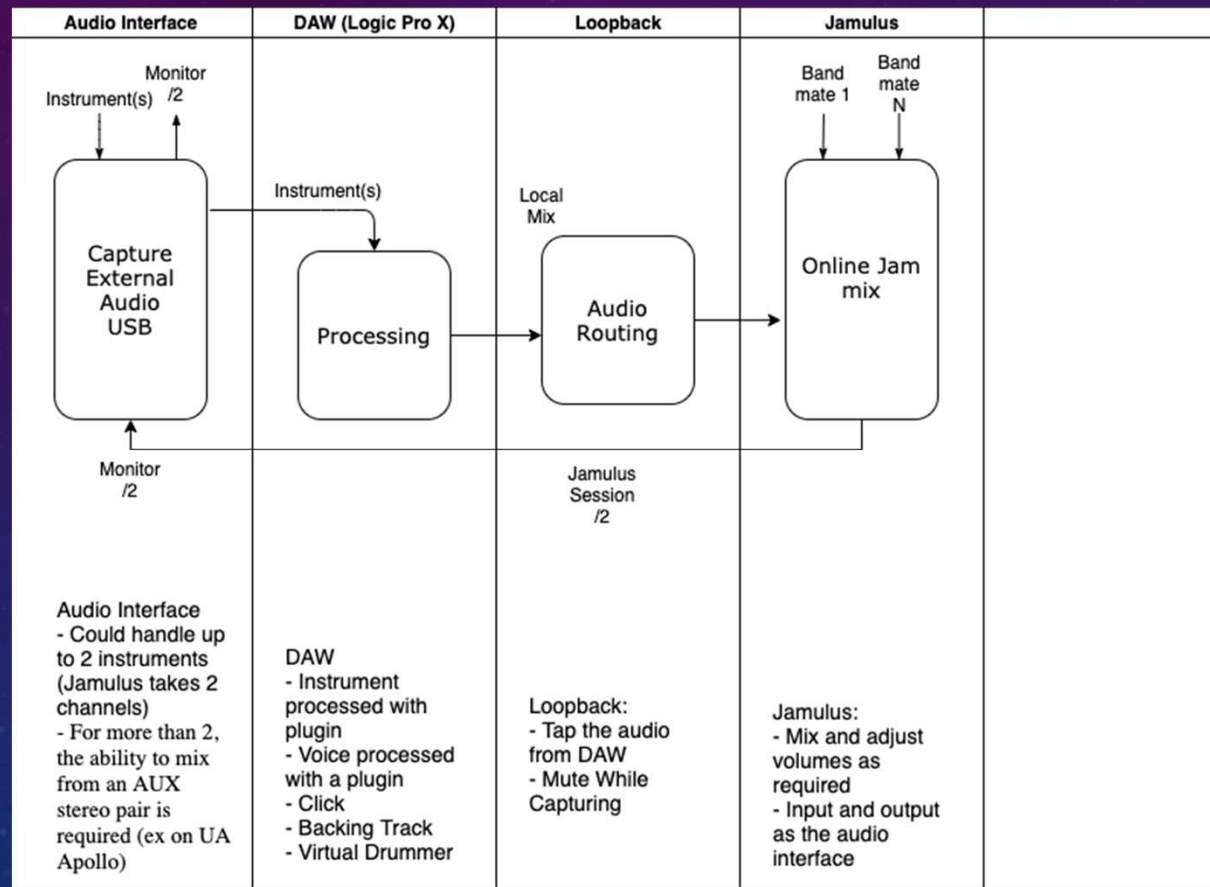

ROUTING OUT TO RECORDING OR LIVESTREAM

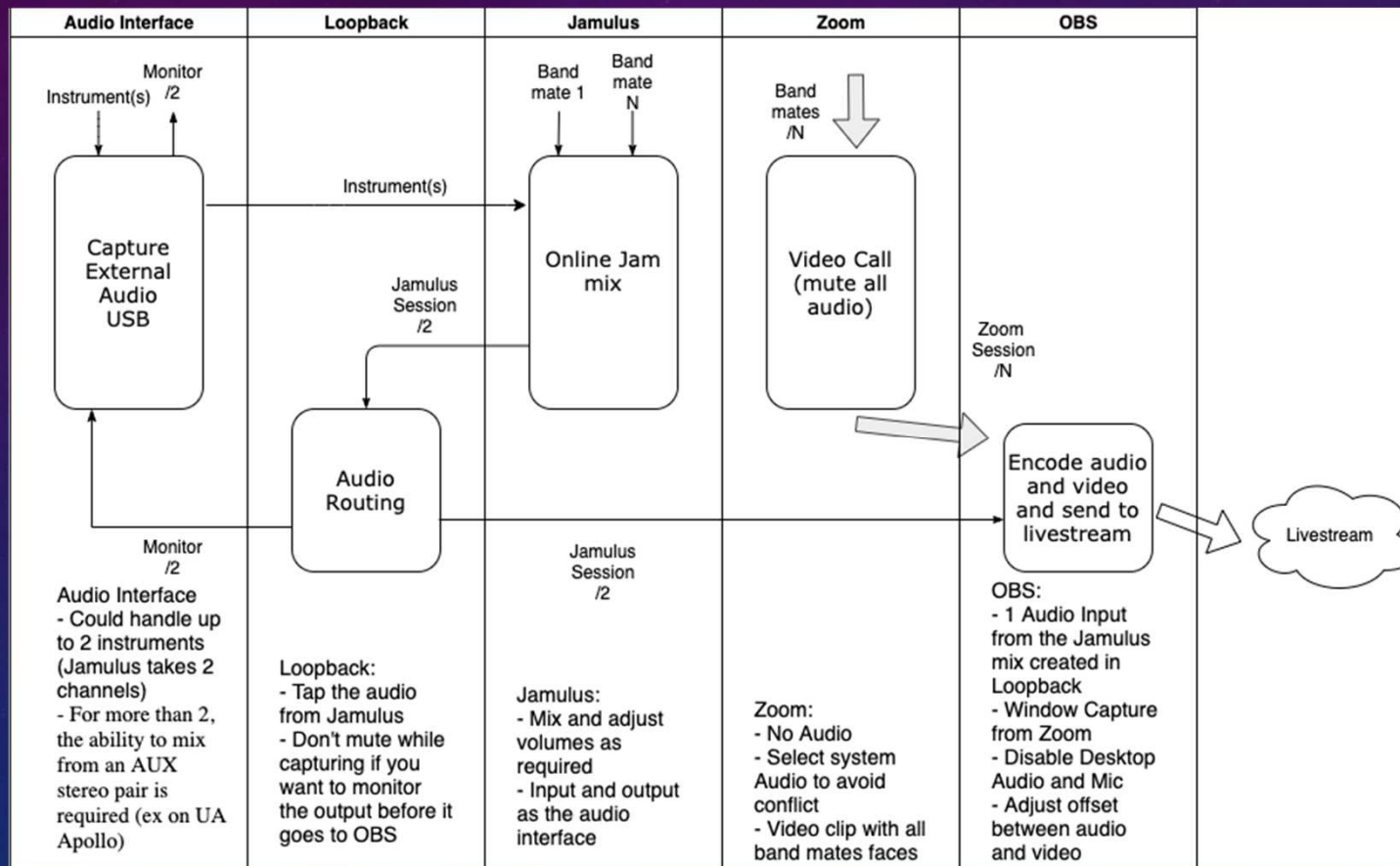

FB GROUP, 'ZOOMULUS EXAMPLE', INFO

- <https://www.facebook.com/groups/507047599870191/>
- <https://m.facebook.com/notes/jamulus-worldjam/howto-idiots-guide-to-installing-or-upgrading-a-jamulus-server-on-amazon-aws-lig/818091045662521/>
- <https://jamulus.io>
- <https://jamulus.io/PerformingBandRehearsalsontheInternetWithJamulus.pdf> (paper on Jamulus)
- <https://jamulus.io/wiki/Tips-Tricks-More> (Additional tips on equipment, audio routing, chord sheets)
- <https://jamulus.io/wiki/Server-Rpi> (Server on Raspberry Pi)
- <https://opus-codec.org>
- <https://searchnetworking.techtarget.com/definition/UDP-User-Datagram-Protocol>
- <https://www.jacktrip.org/technology.html> (Highly recommended as it discussed Client-Server and PtP)
- <https://www.soundjack.eu>
- <http://www.carot.de/Docs/TMT08.pdf> (paper on SoundJack)

FUTURE ?

- Other architectures and network provider partnerships ?
- Leverage on 5G ?
- <https://alohabyelk.com>
- Maybe big names will take over ?
- Virtual rooms for bands ?

The background is a dark blue gradient with a starry space pattern. On the right side, there are several technical diagrams, including a large circular gauge with numerical markings from 0 to 210 and a smaller circular diagram below it. On the left side, there are faint circular diagrams with arrows indicating rotation.

Thank you

contact@audiogeek11.com